

Bianchi

2006



BIKE TRACE.

YOUR BIANCHI IS NOW EVEN MORE YOURS.

BIKE TRACE IS THE PERSONALISED SERVICE WHICH MAKES YOUR NEW BIANCHI REPARTO CORSE BICYCLE EVEN MORE YOURS: IT GUARANTEES AT ANY TIME ITS FULL TRACEABILITY AND IDENTIFICATION AND ALSO PROVIDES VALUABLE ASSISTANCE IN CASE OF THEFT OR LOSS TOO.

LOG ONTO THE WEBSITE **WWW.BIANCHI.COM/BIKETRACE**, FILL IN THE 'TRACE FORM' WITH YOUR PERSONAL DATA AND YOUR FRAME CODE AND YOU WILL HAVE YOUR NEW BIANCHI REPARTO CORSE REGISTERED.

THE FRAME CODE AND INFORMATION REQUIRED FOR THE SERVICE START-UP ARE CONTAINED IN THE **"QUALITY CONTROL REPORT"** COUPON WHICH CAN BE FOUND UNDER SEPARATE COVER TOGETHER WITH THE DOCUMENTS OF YOUR NEW BIANCHI REPARTO CORSE.

IN THE EVENT OF LOSS OF THE **"QUALITY CONTROL REPORT"** COUPON, IT IS POSSIBLE TO REGISTER THE PURCHASED BICYCLE: AS THE FRAME CODE IS STAMPED ON THE FRAME, UNDERNEATH THE BOTTOM BRACKET SHELL. BIKE TRACE ALLOWS EASY USE OF THE SERVICE THROUGH THE WEB EVEN FOR THOSE WHO PURCHASE OR OWN MORE THAN ONE BIANCHI BIKE: THE ON-LINE SERVICE ALLOWS THE REGISTRATION OF MULTIPLE BICYCLES UNDER A SINGLE USER PROFILE.





2006 BIANCHI REPARTO CORSE

HE DOESN'T KNOW COPPI OR RECOGNISES GIMONDI; HE REMEMBERS HIS DAD GOING CRAZY FOR SOMEONE NAMED PANTANI; HE'S ONLY HEARD THE NAMES OF ABSALON AND DI LUCA.

BUT HE ALREADY HAS A BIANCHI IN MIND.

NEW FRAMES / NEW OUTFITS / TECHNOLOGIES AND NEW MATERIAL RESEARCH / SPECIAL MACHINING / UPGRADED TEST METHODS / NEW GEOMETRIES / NEW TUBING DESIGNS FROM EXCLUSIVE R&D PROJECTS / NEW PARTNERSHIPS

THE STORY OF CYCLING IS WRITTEN IN ITS FUTURE.

2006 BIANCHI REPARTO CORSE RANGE: 120 + 1 REASONS TO KEEP ON RACING TOWARDS EVOLUTION.

ROAD

S9 MATTA - The most beloved team car, that of Fausto Coppi.

LIGHT, STIFF AND RESISTANT OVER TIME. THE USE OF GRADE 9 TITANIUM ALLOY (TI 3AL/2.5V), WHICH HAS A TENSILE STRENGTH OF 860N/MM² AND A LIMITED WEIGHT DENSITY, ALLOWS US TO IMPROVE THE SPECIFIC STIFFNESS OF THE FRAME, WHILE MAINTAINING THE LEVEL OF COMFORT TYPICAL OF TITANIUM. AS THE MATERIAL'S LOW COEFFICIENT OF ELASTICITY HAS A CUSHIONING EFFECT OVER ROUGH TERRAIN. THE EXTRUDED DOUBLE-BUTTED TUBING, IN SPECIFIC DIAMETERS AND SECTIONS, COMBINED WITH THE NEW MONOSTAY DESIGN IN HIGH MODULUS CARBON FIBRE (OUR EXCLUSIVE DESIGN FROM BIANCHI REPARTO CORSE) PERMITS US TO FURTHER INCREASE THE PERFORMANCE OF THIS FRAME. THE TIG WELDING IN A PROTECTIVE ATMOSPHERE, ENSURES THE PRESERVATION OF ALL THE MECHANICAL PROPERTIES. THE COMPONENTS (REAR DROP OUTS, HEAD TUBE AND CABLE STOPS) ARE ALL MADE VIA CNC MACHINING.

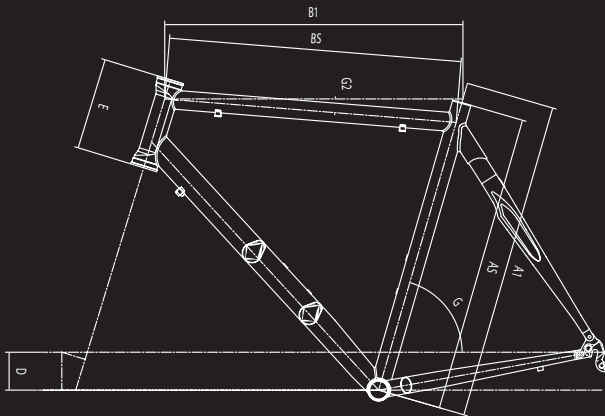

MISSLP							
A1	AS	B1	BS	D	E	G	G2
490	460	523	509	58	110	74.5°	7°
500	470	524	512	58	110	74.5°	6°
510	480	526	515	58	110	74°	5°
520	490	530	520	63	110	74°	4.5°
530	500	535	523	68	125	74°	5.5°
540	510	540	530	68	125	74°	4.5°
550	520	550	538	68	140	73.5°	5°
560	530	555	545	68	140	73.5°	4°
570	540	560	550	68	155	73.5°	5°
580	550	570	560	68	155	73°	4°
590	560	575	563	68	175	73°	5°
600	570	580	570	68	175	73°	4°
610	580	585	572	68	195	72.5°	5°
620	590	590	579	68	195	72.5°	4°
630	600	595	583	68	210	72.5°	4.5°



S9 MATTA RECORD, Y6B18, COLOUR TN - GROUP CAMPAGNOLO RECORD, HANDLEBAR AND STEM ITM K-SWORD CARBON, SEATPOST PMP CARBON, CRANKSET BIANCHI COMPONENTI FULL CARBON, WHEELS CAMPAGNOLO EURUS. **ALSO AVAILABLE IN COLOUR CZ AND AS FRAMESET (X6B02).**

FG - The initials of one of the greatest Bianchi champions: Felice Gimondi.

INCREDIBLY LIGHT AND ORIGINALLY SUITABLE FOR CLIMBERS, THE FRAME HAS NOW EVOLVED INTO A MACHINE SUITABLE FOR EVERYONE EVEN SPRINTERS. THE EXCLUSIVE 7000 SERIES HYPERALLOY ALUMINIUM, ALLOYED WITH ZINC AND MAGNESIUM, USED IN THIS FRAME, IS A POINT OF REFERENCE FOR ALL MATERIAL DESIGNERS YET IS UNBEATABLE ON THE MARKET (HAVING A TENSILE STRENGTH OF 650N/MM²).

THE TRIPLE-BUTTED TUBING (WITH A MINIMUM THICKNESS OF 0,65MM UP TO A MAXIMUM OF 1,15MM), COMBINED WITH THE NEW OVERSIZE SEAT TUBE, WITH A DIAMETER OF 35MM, AND THE NEW MONOSTAY DESIGN IN HIGH MODULUS CARBON FIBRE, STIFFENS THIS EXTRA-LIGHT FRAME, WHICH CAN BE USED AS WELL BY BOTH HEAVY AND STRONG RIDERS, WITHOUT DISSIPATING THE ENERGY USED INTO FRAME DEFORMATION. THE STRUCTURAL FOAM INJECTION, IN THE MOST STRESSED AREAS OF THE FRAME, AND THE PHOSPHOR-CHROMATE SURFACE TREATMENT REMARKABLY INCREASES THE DURABILITY OF THIS EXCLUSIVE FRAME.

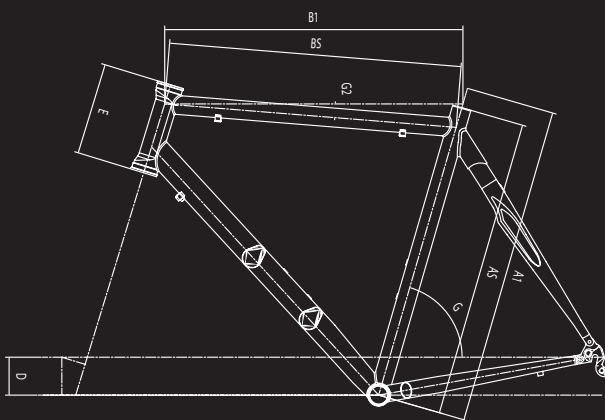

MISSLP							
A1	AS	B1	BS	D	E	G	G2
490	460	523	509	58	110	74.5°	7°
500	470	524	512	58	110	74.5°	6°
510	480	526	515	58	110	74°	5°
520	490	530	520	63	110	74°	4.5°
530	500	535	523	68	125	74°	5.5°
540	510	540	530	68	125	74°	4.5°
550	520	550	538	68	140	73.5°	5°
560	530	555	545	68	140	73.5°	4°
570	540	560	550	68	155	73.5°	5°
580	550	570	560	68	155	73°	4°
590	560	575	563	68	175	73°	5°
600	570	580	570	68	175	73°	4°
610	580	585	572	68	195	72.5°	5°
620	590	590	579	68	195	72.5°	4°
630	600	595	583	68	210	72.5°	4.5°



FG LITE RECORD, Y6B21, COLOUR CZ - GROUP CAMPAGNOLO RECORD, HANDLEBAR, STEM AND SEATPOST ITM K-SWORD CARBON, CRANKSET BIANCHI COMPONENTI FULL CARBON, WHEELS CAMPAGNOLO EURUS. **ALSO AVAILABLE IN COLOUR DK AND AS FRAMESET (X6B01).**



FG LITE DURA ACE, Y6B22, COLOUR DK - GROUP SHIMANO DURA ACE, HANDLEBAR, STEM AND SEATPOST ITM K-SWORD CARBON, CRANKSET BIANCHI COMPONENTI FULL CARBON, WHEELS FULCRUM RACING 1. ALSO AVAILABLE WITH ULTEGRA (Y6B23). ALSO AVAILABLE IN COLOUR CZ AND AS FRAMESET (X6B01).



FRECCIA CELESTE - The legendary Bianchi motorcycle used by the fabulous Tazio Nuvolari.

A UNIQUE FRAME OF A NEW GENERATION MADE WITH HYDROFORMING TECHNOLOGY. THE 7000 SERIES ALUMINIUM, ALLOYED WITH ZN-MG-CU, PERMITS A HIGH MECHANICAL STRENGTH (TENSILE STRENGTH 450N/MM2) COMBINED WITH A GREATER ELONGATION, ALLOWING TUBE MANIPULATION THROUGH HIGH PRESSURE TECHNIQUES.

THE TRIPLE-BUTTED TUBING HAS BEEN DESIGNED USING THE SIMULATION MODE OF FEM (FINITE ELEMENT METHOD) SOFTWARE, IN ORDER TO OBTAIN THE BEST TORSIONAL STIFFNESS OF THE FRAME. THIS RESULTS IN A FRAME WHICH, THANKS TO THE REAR STAYS, MADE ENTIRELY OF CARBON FIBRES ORIENTED TO ALLOW THE DAMPING OF EXCESSIVE VIBRATIONS, PERMITS US TO OBTAIN EXCELLENT PERFORMANCES OF REACTIVITY AND RESPONSE TO SUDDEN DIRECTIONAL CHANGES. THE STRUCTURAL FOAM INJECTION, IN THE MOST STRESSED AREAS, AND THE PHOSPHOR-CHROMATE SURFACE TREATMENT REMARKABLY INCREASES THE DURABILITY OF THIS INNOVATIVE FRAME.

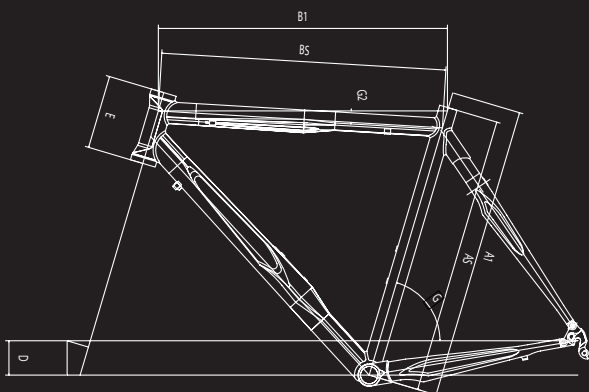

MIS.SLP							
A1	A5	B1	B5	D	E	G	G2
490	460	523	509	58	110	74.5°	7°
500	470	524	512	58	110	74.5°	6°
510	480	526	515	58	110	74°	5°
520	490	530	520	63	110	74°	4.5°
530	500	535	523	68	125	74°	5.5°
540	510	540	530	68	125	74°	4.5°
550	520	550	538	68	140	73.5°	5°
560	530	555	545	68	140	73.5°	4°
570	540	560	550	68	155	73.5°	5°
580	550	570	560	68	155	73°	4°
590	560	575	563	68	175	73°	5°
600	570	580	570	68	175	73°	4°
610	580	585	572	68	195	72.5°	5°
620	590	590	579	68	195	72.5°	4°
630	600	595	583	68	210	72.5°	4.5°



FRECCIA CELESTE HC RECORD, Y6B19, COLOUR CX - GROUP CAMPAGNOLO RECORD, HANDLEBAR AND STEM ITM K-SWORD CARBON, SEATPOST PMP CARBON, CRANKSET BIANCHI COMPONENTI FULL CARBON, WHEELS CAMPAGNOLO EURUS. **ALSO AVAILABLE IN COLOUR KT AND AS FRAMESET (X6B03).**



FRECCIA CELESTE HC MIX 105/ULTEGRA, Y6B20, COLOUR KT - GROUP SHIMANO 105/ULTEGRA, HANDLEBAR ITM MILLENNIUM WINGSHAPE CARBON, STEM ITM FORGED LITE CARBON, SEATPOST FSA SL-K CARBON, CRANKSET BIANCHI COMPONENTI CARBON W. ALU SPIDER, WHEELS FULCRUM RACING 3. **ALSO AVAILABLE IN COLOUR CX AND AS FRAMESET (X6B03).**

FRANCO PELLIZOTTI • COPPI E BARTALI, 23.03.2005



928 - 1949, 1952, 1998: the years in which Bianchi won both the Giro and the Tour in the same year.

HERE CARBON FIBRE RESEARCH REACHES THE PINNACLE OF BOTH DESIGN AND PERFORMANCE. THE USE OF UHM/IM ULTRA HIGH MODULUS GRAPHITE CARBON FIBRES, WHICH ARE 47% MORE RESISTANT THAN THE STANDARD FIBRES CURRENTLY USED IN THE MARKET, FEATURE A TENSILE STRENGTH OF UP TO 2.800 N/MM². DESIGNED AND ORIENTED BY MEANS OF FEM (FINITE ELEMENT METHOD) SOFTWARE, WE ARE ABLE TO REACH LIMITS WHICH ARE UNATTAINABLE BY ISOTROPIC MATERIALS.

THE EXCLUSIVE DESIGN FROM BIANCHI REPARTO CORSE, WHICH COMBINES THE DOWN TUBE AND THE OVERSIZED SEAT TUBE WITH THE REAR MONOSTAY, IMPROVES THE RESISTANCE TO TWISTING AND LATERAL BENDING THUS RESULTING IN A GOOD TRANSFER OF POWER TO THE REAR TRIANGLE. THE PRODUCTION TECHNOLOGY CONSISTS IN THE LAYING OF THE PRE-SHAPED, PRE-SATURATED SINGLE SHEETS ACCORDING TO SPECIFICATIONS, FOLLOWED BY COMPLETE POLYMERIZATION IN A HIGH PRESSURE AUTOCLAVE, TO OBTAIN THE MOST OF THE MECHANICAL PROPERTIES. THE LAST SURFACE FINISHING LAYER (3K WEAVE) IS PUT INTO THE AUTOCLAVE AS WELL, AS IT WILL ENSURE A GOOD RESISTANCE TO BOTH KNOCKS AND WEATHERING CONDITIONS, TO A LEVEL WHICH CAN HARDLY BE ACHIEVED BY THE CONVENTIONAL COATING TECHNIQUES CURRENTLY AVAILABLE ON THE MARKET.

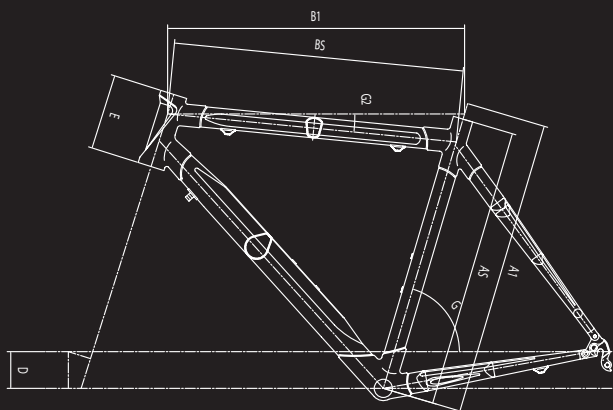

MIS.SLP	A1	AS	B1	BS	D	E	G	G2
490	460	523	509	58	110	74.5°	7°	
500	470	525	512	58	110	74.5°	6°	
510	480	526	514	58	110	74°	5°	
520	490	530	520	63	110	74°	5°	
530	500	535	523	68	125	74°	6°	
540	510	540	530	68	125	74°	5°	
550	520	550	538	68	140	73.5°	5°	
560	530	555	545	68	140	73.5°	4°	
570	540	560	548	68	155	73.5°	5°	
580	550	570	560	68	155	73°	4°	
590	560	575	562	68	175	73°	5°	
600	570	580	569	68	175	73°	4°	
610	580	585	571	68	195	72.5°	5°	
620	590	590	579	68	195	72.5°	4°	
630	600	595	583	68	210	72.5°	4°	

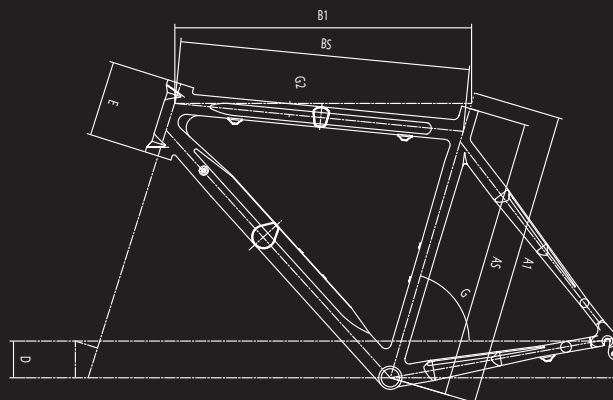

MIS.SLP	A1	AS	B1	BS	D	E	G	G2
500	480	525	511	58	110	74.5°	7°	
530	500	535	522	68	125	74°	6°	
550	520	530	537	68	140	73.5°	6°	
580	550	570	560	68	155	73°	4°	
610	580	585	574	68	195	72.5°	5°	

CARBON L

CARBON



928 CARBON L DURA ACE, Y6B26, COLOUR EL - GROUP SHIMANO DURA ACE, HANDLEBAR AND STEM ITM K-SWORD CARBON, SEATPOST PMP CARBON, CRANKSET BIANCHI COMPONENTI FULL CARBON, WHEELS FULCRUM RACING 1. **ALSO AVAILABLE AS FRAMESET (X6B05).**



928 CARBON L CHORUS, Y6B25, COLOUR EL - GROUP CAMPAGNOLO CHORUS, HANDLEBAR AND STEM ITM 4-EVER SUPER OVER CARBON, SEATPOST FSA SL-K CARBON, CRANKSET BIANCHI COMPONENTI FULL CARBON, WHEELS CAMPAGNOLO ZONDA. **ALSO AVAILABLE WITH RECORD (Y6B24) AND AS FRAMESET (X6B05).**



928 CARBON L ULTEGRA, Y6B01, COLOUR EL - GROUP SHIMANO ULTEGRA, HANDLEBAR AND STEM ITM 4-EVER SUPER OVER CARBON, SEATPOST FSA SL-K CARBON, CRANKSET BIANCHI COMPONENTI CARBON W. ALU SPIDER, WHEELS FULCRUM RACING 3. **ALSO AVAILABLE AS FRAMESET (X6B05).**



928 CARBON MIX 105/ULTEGRA, Y6B27, COLOUR ER - GROUP SHIMANO 105/ULTEGRA, HANDLEBAR ITM MILLENNIUM WINGSHAPE CARBON, STEM ITM FORGED LITE CARBON, SEATPOST FSA SL 280 CARBON PRO, CRANKSET FSA CFM CARBON PRO, WHEELS FULCRUM RACING 5. **ALSO AVAILABLE IN COLOUR EB AND AS FRAMESET (X6B06).**



928 CARBON VELOCE COMPACT, Y6B03, COLOUR EB - GROUP CAMPAGNOLO VELOCE, HANDLEBAR ITM MILLENNIUM WINGSHAPE CARBON, STEM ITM FORGED LITE CARBON, SEATPOST FSA SL 280 CARBON PRO, CRANKSET FSA GOSSAMER COMPACT MEGA EXO, WHEELS FULCRUM RACING 5. **ALSO AVAILABLE WITH DOUBLE 53/39 RINGS (Y6B04), WITH CENTAUR (Y6B02) AND ALSO AVAILABLE IN COLOUR ER AND AS FRAMESET (X6B06).**

1885 - The year the "Mechanical Workshop Edoardo Bianchi" was founded.

REDESIGNED AFTER THE EXPERIENCE ACQUIRED WITH THE HYDROFORMING TECHNOLOGY, THE FRAME HAS BEEN SLIMMED DOWN WHILE KEEPING IT'S PERFORMANCE CHARACTERISTICS UNCHANGED. CONSTRUCTED FROM AERONAUTIC GRADE 7000 SERIES ALUMINIUM, WITH RESISTANCE FEATURES COMPARABLE TO THOSE OF STEEL YET WITH 1/3 DENSITY, IT ENABLES THE REPARTO CORSE DESIGNERS TO WORK OUT TUBE SECTIONS AND GAUGES, OBTAINING AN APPEALING DESIGN WITH HIGH LEVELS OF PERFORMANCE AND LIMITED WEIGHT. TUBES ARE DOUBLE- AND TRIPLE-BUTTED AND THE CARBON FIBRE SEAT STAYS ALLOW THE DISSIPATION OF VIBRATIONS COMING FROM THE GROUND TO ALLOW FOR A MORE COMFORTABLE FRAME. THE SMOOTH TIG WELDING GIVES AN EXCELLENT AESTHETIC FINISH, AS WELL AS, AVOIDING EXTRA STRAIN IN THE MOST STRESSED AREAS OF THE FRAME. A SPECIAL ANTI-CORROSION SURFACE TREATMENT CARRIED OUT BEFORE PAINTING ENSURES LONG TERM DURABILITY.

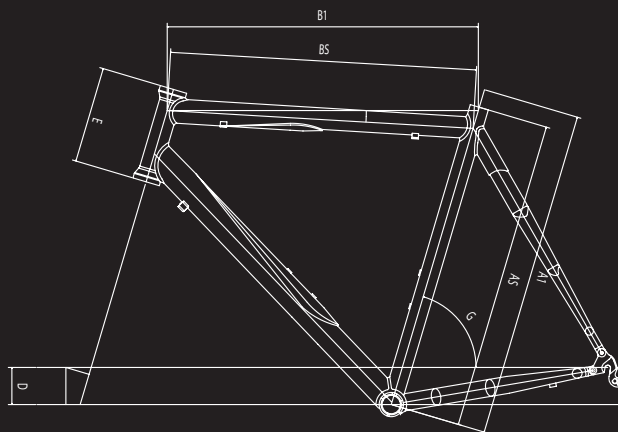

MIS.SLP							
A1	AS	B1	B5	D	E	G	G2
490	460	523	510	58	110	74.5°	6°
510	480	527	517	58	110	74°	4.5°
530	500	535	524	68	125	74°	5°
550	520	550	538	68	140	73.5°	5°
570	540	560	549	68	155	73.5°	4.5°
590	560	575	563	68	175	73°	4.5°
610	580	585	572	68	195	72.5°	4.5°
630	600	595	583	68	210	72.5°	4°



1885 TB HYDRO CARBON ULTEGRA COMPACT, Y6B06, COLOUR CZ - GROUP SHIMANO ULTEGRA, HANDLEBAR ITM MILLENNIUM WINGSHAPE CARBON, STEM ITM FORGED LITE CARBON, SEATPOST SELCOF 91A CARBON, CRANKSET FSA CFM CARBON PRO, WHEELS FULCRUM RACING 5. ALSO AVAILABLE WITH DOUBLE 53/39 RINGS (Y6B05), IN COLOUR WG AND AS FRAMESET (X6B08).



1885 TB HYDRO CARBON CENTAUR TRIPLE, Y6B07, COLOUR WG - GROUP CAMPAGNOLO CENTAUR, HANDLEBAR ITM LITE LUXE WINGSHAPE, STEM BIANCHI COMPONENTI 3-D FORGED ALLOY SUPER OVER, SEATPOST SELCOF 91A CARBON, CRANKSET CAMPAGNOLO VELOCE TRIPLE, WHEELS FULCRUM RACING 5. **ALSO AVAILABLE WITH COMPACT 50/34 RINGS (Y6B08), IN COLOUR CZ AND AS FRAMESET (X6B08).**

VERA CARRARA - LOS ANGELES, 25.03.2005



DAMA BIANCA - The fairy lady by the side of Fausto Coppi.

REDESIGNED AFTER THE EXPERIENCE ACQUIRED WITH THE HYDROFORMING TECHNOLOGY AND IN TUNE WITH THE BIANCHI WOMENS PRO TEAM; TEAM BIANCHI-ALIVERTI, IT RECONFIRMS WHAT HAS BECOME A SUCCESSFUL DESIGN. CONSTRUCTED FROM 7000 SERIES ALUMINIUM ALLOY UNDERGOING A SPECIAL TYPE OF T6 HEAT TREATMENT, IT ENSURES AN EXCELLENT WEIGHT/STIFFNESS RATIO COMBINED WITH A HIGH COEFFICIENT OF ELASTICITY.

THE TUBES ARE DOUBLE- AND TRIPLE-BUTTED WITH GEOMETRY BASED ON FEMALE BODY MEASUREMENTS AND WITH THE ADVICE OF OUR WOMEN PROFESSIONAL RIDERS. THE SMOOTH TIG WELDING GIVES AN EXCELLENT AESTHETIC FINISH, AS WELL AS, AVOIDING EXTRA STRAIN IN THE MOST STRESSED AREAS OF THE FRAME. A SPECIAL ANTI-CORROSION SURFACE TREATMENT CARRIED OUT BEFORE PAINTING ENSURES LONG TERM DURABILITY.

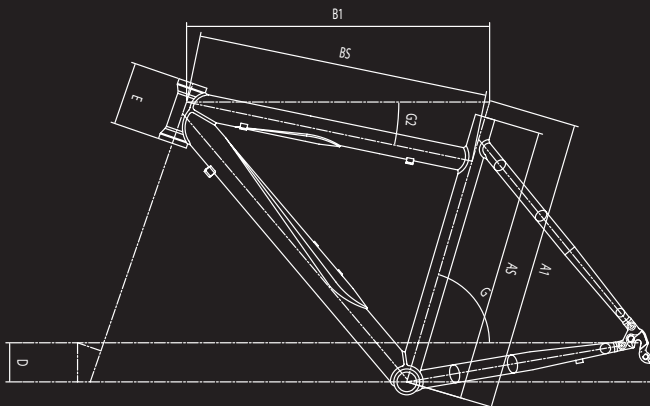

MIS SLP							
A1	AS	B1	BS	D	E	G	G2
460	430	521	504	58	100	74,5°	13°
490	460	523	509	58	110	74,5°	12°
510	480	527	516	58	110	74°	9°
530	500	535	523	68	125	74°	10°



DAMA BIANCA HA VELOCE TRIPLE, Y6B09, COLOUR IC - GROUP CAMPAGNOLO VELOCE, HANDLEBAR ITM ELLE, STEM BIANCHI COMPONENTI 3-D FORGED ALLOY SUPER OVER, SEATPOST BIANCHI SP-151, CRANKSET FSA CFM-335-A TRIPLE, WHEELS BIANCHI COMPONENTI RACING.

VIA NIRONE 7 - The address of Edoardo Bianchi's first shop in Milan.

THE REVISED TUBE THICKNESSES MAKE THIS FRAME A REMARKABLE POINT OF REFERENCE THANKS TO ITS HIGH PERFORMANCE/WEIGHT RATIO.

CONSTRUCTED FROM AERONAUTIC GRADE 7000 SERIES ALUMINIUM ALLOY, WITH A TENSILE STRENGTH OF 450N/MM² AND A SPECIFIC DENSITY OF 2,7KG/DM³.

THE DOUBLE-BUTTED TUBES ARE DESIGNED TO SAVE WEIGHT WHERE PERMITTED BY THE STRESS CONDITIONS. IT IS AVAILABLE IN TWO VERSIONS ONE WITH CARBON SEAT STAYS THE OTHER IN FULL ALUMINIUM.

BOTH ARE MADE WITH THE NEW OVERSIZE SEAT TUBE WITH A 35 MM DIAMETER, THE MODEL WITH THE NEW CARBON MONOSTAY, AN EXCLUSIVE DESIGN FROM BIANCHI REPARTO CORSE, ALLOWS THIS FRAME TO BE MORE COMFORTABLE THANKS TO AN EXTREMELY COMPACT AND REACTIVE REAR TRIANGLE.

THE SMOOTH TIG WELDING GIVES AN EXCELLENT AESTHETIC FINISH, AS WELL AS AVOIDING EXTRA STRAIN IN THE MOST STRESSED AREAS OF THE FRAME. A SPECIAL ANTI-CORROSION SURFACE TREATMENT CARRIED OUT BEFORE PAINTING ENSURES LONG TERM DURABILITY.

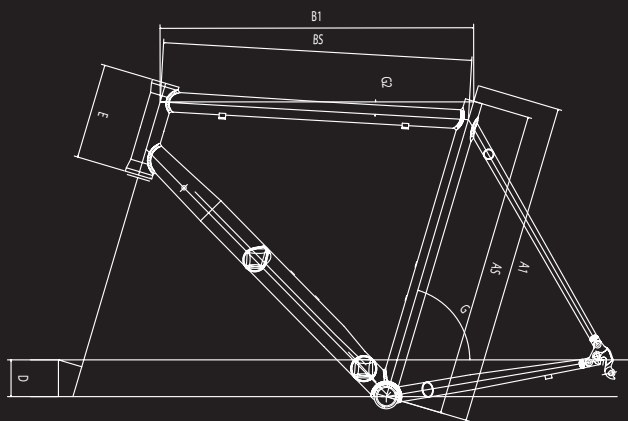

MIS SLP							
A1	AS	B1	BS	D	E	G	G2
460	440	520	505	58	110	74.5°	9°
500	470	524	512	58	110	74.5°	5°
530	500	535	523	68	125	74°	5°
550	520	550	538	68	140	73.5°	5°
570	540	560	549	68	155	73.5°	4.5°
590	560	575	563	68	175	73°	4.5°
610	580	585	572	68	195	72.5°	4.5°

ALU CARBON

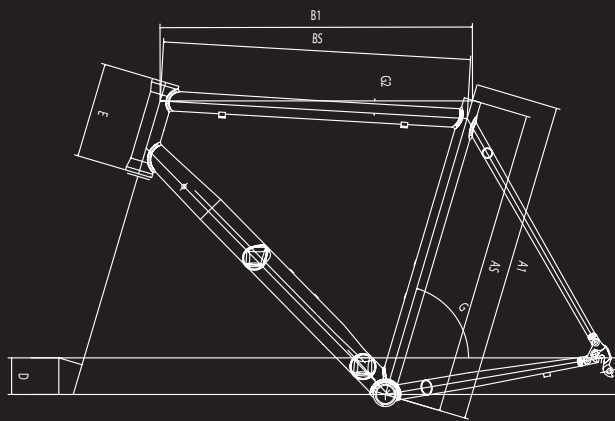

MIS SLP							
A1	AS	B1	BS	D	E	G	G2
460	440	520	505	58	110	74.5°	9°
500	470	524	512	58	110	74.5°	5°
530	500	535	523	68	125	74°	5°
550	520	550	538	68	140	73.5°	5°
570	540	560	549	68	155	73.5°	4.5°
590	560	575	563	68	175	73°	4.5°
610	580	585	572	68	195	72.5°	4.5°

ALUMINIUM



VIA NIRONE 7 ALU CARBON MIX ULTEGRA/105 DOUBLE, Y6B28, COLOUR CY - GROUP SHIMANO ULTEGRA/105, HANDLEBAR ITM LITE LUXE WINGSHAPE, STEM BIANCHI COMPONENTI 3-D FORGED ALLOY SUPER OVER, SEATPOST BIANCHI SP-151, CRANKSET FSA GOSSAMER DOUBLE MEGA EXO, WHEELS SHIMANO WH-R500. **ALSO AVAILABLE WITH TRIPLE 50/39/30 (Y6B29), IN COLOUR PA AND AS FRAMESET (X6B09).**



VIA NIRONE 7 ALU CARBON VELOCE COMPACT, Y6B11, COLOUR PA - GROUP CAMPAGNOLO VELOCE, HANDLEBAR ITM LITE LUXE WINGSHAPE, STEM BIANCHI COMPONENTI 3-D FORGED ALLOY SUPER OVER, SEATPOST BIANCHI SP-151, CRANKSET FSA GOSSAMER COMPACT MEGA EXO, WHEELS BIANCHI COMPONENTI RACING. **ALSO AVAILABLE WITH DOUBLE 53/39 RINGS (Y6B10), IN COLOUR CY AND AS FRAMESET (X6B09).**



VIA NIRONE 7 ALU CARBON MIRAGE TRIPLE, Y6B13, COLOUR CY - GROUP CAMPAGNOLO MIRAGE, HANDLEBAR ITM LITE LUXE WINGSHAPE, STEM BIANCHI COMPONENTI 3-D FORGED ALLOY SUPER OVER, SEATPOST BIANCHI SP-151, CRANKSET FSA CFM-335-A TRIPLE, WHEELS BIANCHI COMPONENTI RACING. **ALSO AVAILABLE WITH DOUBLE 53/39 RINGS (Y6B12), IN COLOUR PA AND AS FRAMESET (X6B09).**



VIA NIRONE 7 XENON COMPACT, Y6B14, COLOUR SL - GROUP CAMPAGNOLO XENON, HANDLEBAR ITM 330 SUPER OVER, STEM BIANCHI COMPONENTI 3-D FORGED ALLOY SUPER OVER, SEATPOST BIANCHI SP-151, CRANKSET FSA CFJ-215 COMPACT, WHEELS BIANCHI COMPONENTI RACING. **ALSO AVAILABLE WITH TRIPLE 52/42/30 (Y6B15) AND IN COLOUR CY.**



VIA NIRONE 7 SORA TRIPLE, Y6B17, COLOUR CY - GROUP SHIMANO SORA, HANDLEBAR ITM 330 SUPER OVER, STEM BIANCHI COMPONENTI 3-D FORGED ALLOY SUPER OVER, SEATPOST BIANCHI SP-151, FSA CRD-335 TRIPLE, WHEELS BIANCHI COMPONENTI TEAM. **ALSO AVAILABLE WITH DOUBLE 53/39 RINGS (Y6B16) AND IN COLOUR SL.**

MTB

OETZI - Our most popular ancestor, the man of Similaun. A man of the mountains, nimble and tough, just like this cycle.

OETZI ALU CARBON - DESIGNED BY BIANCHI'S REPARTO CORSE ENGINEERS IN COOPERATION WITH ITS RIDERS, THIS FRAME IS MADE WITH A VERY SPECIAL ALUMINIUM ALLOY. STUDYING DIFFERENTIATED SECTIONS AND MOMENTS OF INERTIA, THE TRIPLE-BUTTED TUBES COMBINED WITH CARBON FIBRE SEAT STAYS, FOLLOWS THE REPARTO CORSE EXCLUSIVE DESIGN. THE CROSS COUNTRY GEOMETRY IS OPTIMISED FOR COMPETITION. THE STRUCTURAL FOAM INJECTION, FOUND IN THE MOST STRESSED AREAS OF THE FRAME, ALONG WITH THE PHOSPHOR-CHROMATE SURFACE TREATMENT, REMARKABLY INCREASING THE FRAMES DURABILITY, MAKES THIS A TRULY UNIQUE FRAME.

OETZI CARBON - THE USE OF UHM/IM - ULTRA HIGH MODULUS GRAPHITE CARBON FIBRE IS ALSO AN EXCELLENT SOLUTION FOR AN OFF-ROAD MACHINE. THE AUTOCLAVED MONOCOQUE TECHNOLOGY AND THE MONOSTAY DESIGN WITH VARIABLE DIMENSIONS AND POSITION AND ORIENTATION OF EACH OF THE CARBON LAYERS, ALLOWS US TO OBTAIN BOTH TORSIONAL AND LATERAL STIFFNESS, WHILE MAINTAINING A REMARKABLE COMFORT EFFECT OVER SEVERE TERRAIN.

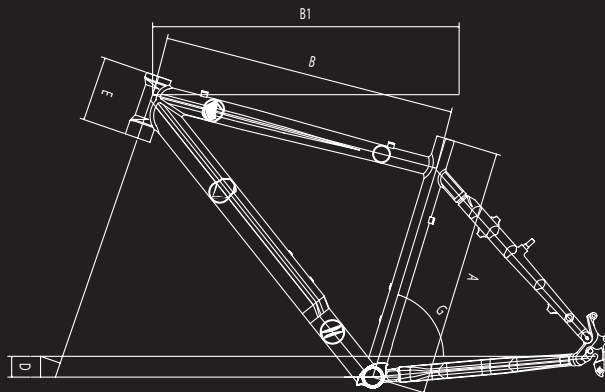

MIS.	A	B1	B5	D	E	G
380	540	525	40	125	73°	
430	570	546	40	125	73°	
480	590	565	40	125	73°	
530	615	593	40	135	73°	

ALU CARBON

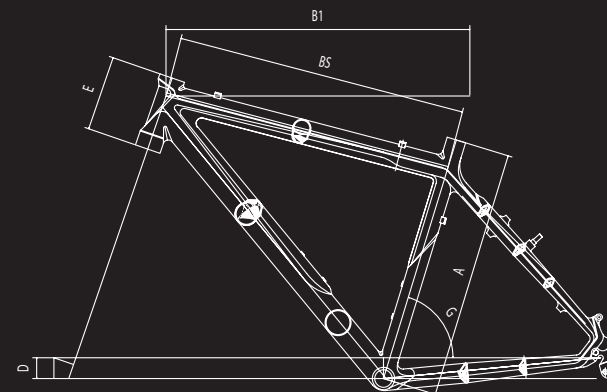

MIS.	A	B1	B5	D	E	G
380	540	525	40	125	73°	
430	570	546	40	125	73°	
480	590	565	40	125	73°	
530	615	593	40	135	73°	

CARBON



OETZI 9800 XL ALUMINIUM CARBON SRAM X.O DISC, Y6B54, COLOUR DB - GROUP SRAM X.O, FORK ROCKSHOX SID TEAM, HANDLEBAR DEDA BIG N'BAR, STEM DEDA NEWTON SUPER OVER, SEATPOST FSA CARBON SL-K, BRAKES AVID JUICY CARBON DISC, CRANKSET FSA CARBON PRO TEAM ISSUE, WHEELS DT XR1540. ALSO AVAILABLE IN COLOUR MG AND AS FRAMESET (X6B50).



OETZI 9600 XL ALUMINIUM CARBON XT DISC, Y6B55, COLOUR MG - GROUP SHIMANO XT, FORK ROCKSHOX SID RACE, HANDLEBAR DEDA BIG N'BAR, STEM DEDA NEWTON SUPER OVER, SEATPOST SELCOF 91A CARBON, BRAKES SHIMANO XT DISC, CRANKSET FSA CARBON PRO TEAM ISSUE, WHEELS DT XR1540. **ALSO AVAILABLE IN COLOUR DB AND AS FRAMESET (X6B50).**



OETZI 9200 XL ALUMINIUM CARBON LX DISC, Y6B56, COLOUR DB - GROUP SHIMANO LX, FORK MANITOU SPLICE PLATINUM AIR, HANDLEBAR FSA XC-180 OS, STEM FSA OS150 LX SUPER OVER, SEATPOST SELCOF 91A CARBON, BRAKES SHIMANO LX DISC, CRANKSET SHIMANO LX, WHEELS DT WIZARD XR4.1. **ALSO AVAILABLE IN COLOUR MG AND AS FRAMESET (X6B50).**



OETZI 9500 XL CARBON XTR/XT DISC, Y6B57, COLOUR EM - GROUP SHIMANO XTR/XT, FORK ROCKSHOX SID RACE, HANDLEBAR FSA XC-180 OS, STEM FSA OS150 LX SUPER OVER, SEATPOST SELCOF 91A CARBON, BRAKES SHIMANO XT DISC, CRANKSET FSA CARBON PRO TEAM ISSUE, WHEELS DT WIZARD XR4.1. **ALSO AVAILABLE AS FRAMESET (X6B52).**



OETZI 9300 XL CARBON XT/LX, Y6B50, COLOUR EM - GROUP SHIMANO XT/LX, FORK MANITOU SPLICE PLATINUM AIR, HANDLEBAR FSA XC-180 OS, STEM FSA OS150 LX SUPER OVER, SEATPOST SELCOF 91A CARBON, BRAKES AVID SINGLE DIGIT 7, CRANKSET SHIMANO LX, WHEELS DT WIZARD XR4.1. **ALSO AVAILABLE AS FRAMESET (X6B52).**

MUTT / DOSS - 2 names from the ancient language which recalls the prehistory of our area. The places where Bianchi was born.

CONSTRUCTED IN 7000 SERIES ALUMINIUM ALLOY, FEATURING A COMBINATION OF DOUBLE- AND TRIPLE-BUTTED TUBES, WITH THE DOWN TUBE MANUFACTURED USING THE HYDROFORMING TECHNIQUE, FOLLOWS BIANCHI REPARTO CORSE'S DESIGN CRITERIA OF ACHIEVING THE BEST IN TERMS OF REACTIVITY AND STIFFNESS.

THE SMOOTH TIG WELDING TECHNIQUE ENSURES A BETTER DISTRIBUTION OF THE STRESSES AND WEAR RESISTANCE. THE FRAME IS THEN HEAT TREATED TO GET THE BEST OF THE MECHANICAL PROPERTIES OF THE MATERIAL AND A SPECIAL ANTI-CORROSION SURFACE TREATMENT IS THEN ADDED.

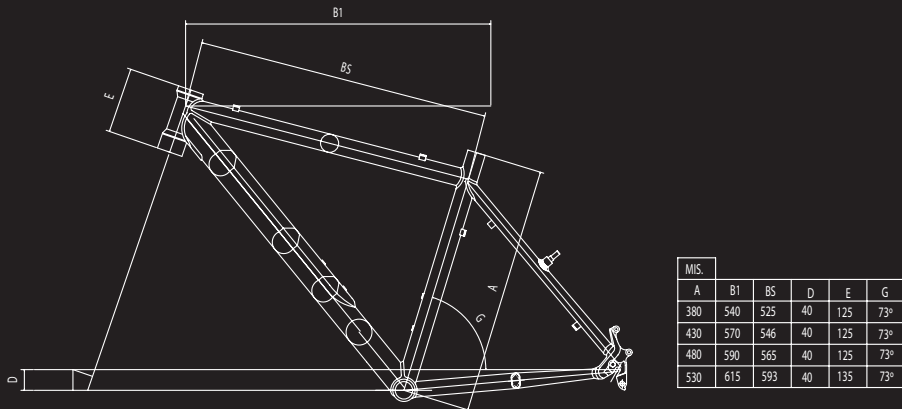



MUTT 7700 XT/DEORE DISC, Y6B51, COLOUR KW - GROUP SHIMANO XT/LX, FORK MANITOU SPLICE COMP, HANDLEBAR FSA XC-180 OS, STEM FSA OS150 LX SUPER OVER, SEATPOST FSA SL-280, BRAKES SHIMANO DEORE DISC, CRANKSET FSA AFTERBURNER MEGAEXO, WHEELS DEORE/MAVIC 317. **ALSO AVAILABLE WITH XT/LX (Y6B58), IN COLOUR DB AND AS FRAMESET (X6B53).**



MUTT 7400 LX/DEORE DISC, Y6B59, COLOUR DB - GROUP SHIMANO LX/DEORE, FORK ROCKSHOX J3, HANDLEBAR FSA XC-280 OS, STEM FSA OS150 LX SUPER OVER, SEATPOST FSA SL-280, BRAKES SHIMANO DEORE DISC, CRANKSET SHIMANO DEORE, WHEELS DEORE/MAVIC 317. **ALSO AVAILABLE WITH V-BRAKES (Y6B60), IN COLOUR KW AND AS FRAMESET (X6B53).**



**MUTT / DOSS - 2 names from the ancient language which recalls the prehistory of our area.
The places where Bianchi was born.**

A FRAME MADE OF SPECIAL ALUMINIUM ALLOY WITH ZINC AND MAGNESIUM, FEATURING A NEW GENERATION DOWN TUBE AND AN OVERSIZED SEAT TUBE INCREASING MANOEUVRABILITY AND CONTROL. THE SMOOTH TIG WELDING TECHNIQUE ENSURES A BETTER DISTRIBUTION OF THE STRESSES AND WEAR RESISTANCE. THE FRAME IS THEN HEAT TREATED TO GET THE BEST OF THE MECHANICAL PROPERTIES OF THE MATERIAL AND A SPECIAL ANTI-CORROSION SURFACE TREATMENT IS THEN ADDED.

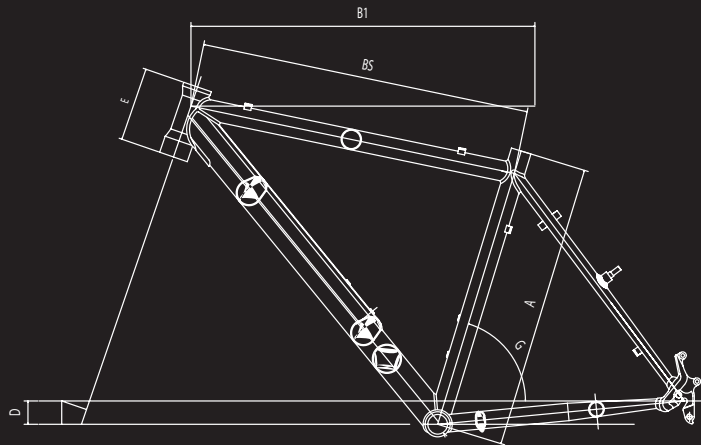

MIS.	A	B1	BS	D	E	G
380	540	525	40	125	73°	
430	570	546	40	125	73°	
480	590	565	40	125	73°	
530	615	593	40	135	73°	



DOSS 6400 DEORE, Y6B62, COLOUR MG - GROUP SHIMANO DEORE, FORK SUN TOUR SF5 AXXON DR-L, HANDLEBAR BIANCHI COMPONENTI F3-AL, STEM BIANCHI COMPONENTI DA-35, SEATPOST BIANCHI COMPONENTI SP-151, BRAKES SHIMANO V-BRAKES B-RM421, CRANKSET FSA FSA ALPHA DRIVE, WHEELS DEORE/AMBROSIO KEBE. **ALSO AVAILABLE WITH DEORE DISC BRAKES (Y6B61) AND IN COLOUR NT.**



DOSS 6500 SRAM 5.0 DISC, Y6B52, COLOUR NT - GROUP SRAM 5.0, FORK SUN TOUR SF5 AXON DR-L, HANDLEBAR BIANCHI COMPONENTI F3-AL, STEM BIANCHI COMPONENTI DA-35, SEATPOST BIANCHI COMPONENTI SP-151, BRAKES AVID JUICY FIVE DISC, CRANKSET FSA ALPHA DRIVE, WHEELS DEORE/AMBROSIO KEBA. **ALSO AVAILABLE WITH V-BRAKES (Y6B53) AND IN COLOUR MG.**



THOMAS DIETSCH - NALLES, 02.04.2005

SPORT

CAMALEONTE - The animal or the bike which suits every situation.

IT'S NO SECRET, IT'S ALL OVER TOWN. CAMALEONTE: THE FAMILY OF SPORTS BIKES WHICH EPITOMIZE THE BEST IN ROAD PHILOSOPHY COMBINED WITH THE NERVES OF RIDING OFF-ROAD: ERGONOMIC, RESPONSIVE AND COMFORTABLE FOR EVERYDAY RIDERS.

A DYNAMIC AND RELIABLE FRAME, RECOMMENDED FOR THOSE IN SEARCH OF RELAXING FREQUENT OUTINGS AND/OR LONG DISTANCES.

THE FRAME IS CONSTRUCTED IN 7000 SERIES ALUMINIUM ALLOY ACCORDING TO BIANCHI'S R&D EXCLUSIVE DESIGN, FEATURING UNISEX SLOPING GEOMETRIES WHICH FOLLOW THE SPECIFICATIONS LAID DOWN BY REPARTO CORSE.

THE NEWLY DESIGNED DOWN TUBE AND THE OVERSIZE SEAT TUBE (Ø 35 MM) MAKE IT A VERY SPECIAL SPORT BIKE, BRILLIANT AND UNBOWED. FORKS IN ALUMINIUM ARE FROM THE BIANCHI COMPONENTI RANGE, WITH AN ADJUSTABLE HANDLEBAR STEM, ROYAL VIPER SADDLE, SEMI-INTEGRATED HEAD SET (1 1/8" COMPACT STEERING SYSTEM) AND FULCRUM RACING 5 WHEELS. SMOOTH TIG WELDING TECHNIQUE. AN ANTI-CORROSION SURFACE TREATMENT ENSURES DURABILITY.

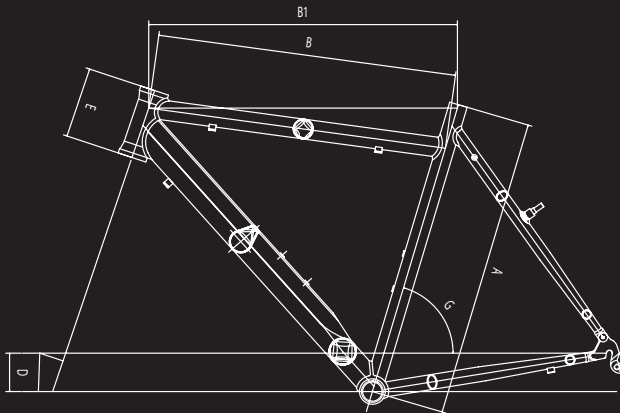

MIS.	A	B1	B	D	E	G
430	520	500	65	100	74.5°	
480	540	520	65	110	74°	
530	555	540	65	125	74°	
580	585	570	65	155	73°	

V-BRAKES

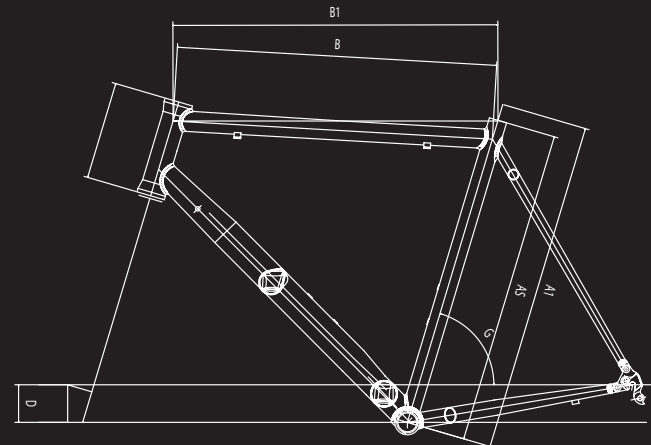

MIS.SLP	A1	AS	B1	B	D	E	G
500	470	524	512	58	110	74.5°	
530	500	535	523	68	125	74°	
550	520	550	538	68	140	73.5°	
590	560	575	563	68	175	73°	

ROAD BRAKES



CAMALEONTE 4 VELOCE TRIPLE, Y6B90, COLOUR CK - GROUP CAMPAGNOLO VELOCE, FORK BIANCHI CARBON/ALU, STEM ADJUSTABLE, CRANKSET CAMPAGNOLO VELOCE, WHEELS FULCRUM RACING 5. ALSO AVAILABLE IN COLOUR KW.



CAMALEONTE 3 MIRAGE TRIPLE, Y6B91, COLOUR KW - GROUP MIRAGE/XENON, FORK BIANCHI KRF 28 ALLOY, STEM ADJUSTABLE, CRANKSET FSA CFM 335 TRIPLE, WHEELS BIANCHI COMPONENTI RACING. ALSO AVAILABLE IN COLOUR CK.



CAMALEONTE 2 SORA TRIPLE UNISEX, Y6B92, COLOUR CK - GROUP SORA, FORK BIANCHI KRF 28 ALLOY, STEM ADJUSTABLE, CRANKSET SHIMANO SORA TRIPLE, WHEELS BIANCHI COMPONENTI RACING. ALSO AVAILABLE IN COLOUR KW.

FRAMESET

D2 - The first Bianchi bicycle to win an international competition. It was the year 1899.

D2 CRONO CARBON - THE NEW MONOCOQUE FRAME IN UHM/IM ULTRA HIGH MODULUS GRAPHITE CARBON FIBRE HAS BEEN DESIGNED WITH THE HELP OF STATE OF THE ART SOFTWARE AND WITH THE COOPERATION OF THE MOST DEMANDING PROFESSIONAL ATHLETES.

DUE TO THE FEM (FINITE ELEMENT METHOD) ANALYSIS AND OTHER SPECIFIC TESTS CARRIED OUT IN THE LABORATORY, WIND TUNNEL AND ON THE ROAD, HAS ENABLED THE DESIGNERS OF REPARTO CORSE TO OBTAIN THE BEST RESULTS IN TERMS OF POWER TRANSFER AND AERODYNAMICS.

D2 PISTA CARBON - THE NEW MONOCOQUE FRAME IN UHM/IM ULTRA HIGH MODULUS GRAPHITE CARBON FIBRE HAS BEEN DESIGNED WITH THE HELP OF STATE OF THE ART SOFTWARE AND WITH THE COOPERATION OF THE MOST DEMANDING PROFESSIONAL ATHLETES. DUE TO THE FEM (FINITE ELEMENT METHOD) ANALYSIS AND THE SPECIFIC LAYING OF THE CARBON FIBRES IT ENSURES THE UTMOST IN STIFFNESS AND RIGIDITY, WHICH IS FUNDAMENTAL FOR THIS KIND OF COMPETITION.

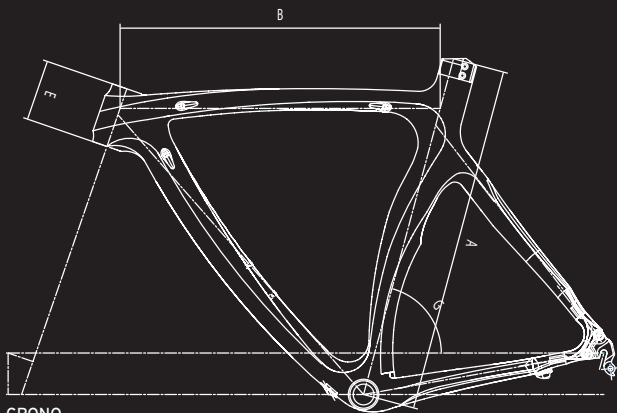

MIS.	A	B	D	E	G
S	570	525	68	100	75°
M	620	545	68	110	74°
L	670	575	68	120	74°

CRONO

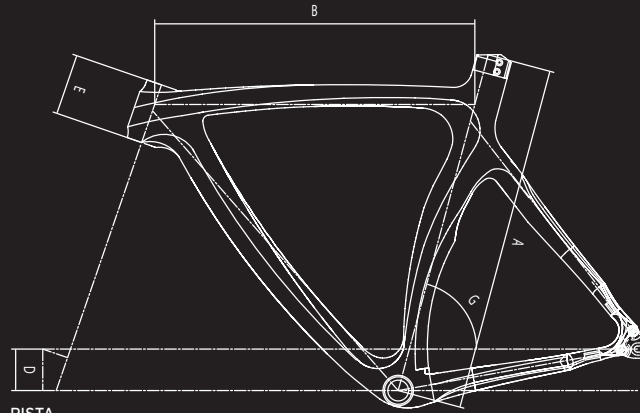

MIS.	A	B	D	E	G
S	570	525	68	100	75°
M	620	545	68	110	74°
L	670	575	68	120	74°

PISTA

D2 CRONO CARBON, X6B12, COLOUR EK. ALSO AVAILABLE AS PISTA FRAMESET (X6B13).

D2 CRONO ALU - (X6B16, COLOUR CZ, PICTURE AVAILABLE ON WWW.BIANCHI.COM)
LONG YEARS OF EXPERIENCE CONFIRM THAT ALUMINIUM IS AN EXCELLENT MATERIAL FOR TIME-TRIALS, ABLE TO BE MADE INTO A RIGID AND AERODYNAMIC STRUCTURE. THIS FRAME IS MADE FROM A SPECIAL ALUMINIUM ALLOY WITH ZINC AND MAGNESIUM, IT COMBINES BOTH DOUBLE- AND TRIPLE-BUTTED TUBES, ENABLING US TO DESIGN THIS FRAME FOR MAXIMUM PERFORMANCE. THE POSSIBILITY OF CUSTOM MADE GEOMETRY TO SUIT ANY SINGLE RIDER, MAKES IT A STANDING POINT WITHIN THE CELESTE RANGE.

D2 PISTA ALU - (X6B11, COLOUR CZ, PICTURE AVAILABLE ON WWW.BIANCHI.COM)
CONSTRUCTED FROM SPECIAL 7000 SERIES ALUMINIUM ALLOY, WITH THE COMBINATION OF DOUBLE- AND TRIPLE-BUTTED TUBES IT ALLOWS AN IMPROVED PERFORMANCE AND HAS A HIGH RIGIDITY/WEIGHT INDEX. IT CAN BE CUSTOM-MADE ACCORDING TO THE BODY MEASUREMENTS OF ANY SINGLE RIDER.

D2 CICLOCROSS

CONSTRUCTED FROM A SPECIAL ALUMINIUM ALLOY WITH GEOMETRY SPECIALLY DESIGNED BY REPARTO CORSE, THANKS ALSO TO THE EXPERIENCE ACQUIRED FROM BIANCHI'S MTB TEAM, IT GAINS LIGHTNESS AND STABILITY (COMBINING DOUBLE- AND TRIPLE-BUTTED TUBES), THANKS TO THE EXTREMELY MANIPULATED REAR TRIANGLE, AN ESSENTIAL FEATURE IN OFF-ROAD MACHINES.

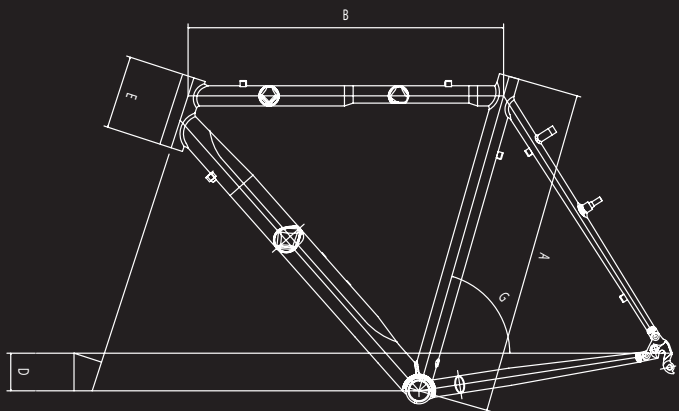

MIS.	A	B	D	E	G
490	525	65	100	74°	
520	530	65	115	74°	
550	550	65	115	74°	
580	560	65	140	74°	
610	585	65	165	72.5°	

D2 CICLOCROSS, X6B14, COLOUR CZ

ROAD FRAMESET

FRECCIA CELESTE HA - The legendary Bianchi motorcycle used by the fabulous Tazio Nuvolari.

AN EXTREME FRAME DESIGNED FOR THE MOST DEMANDING ATHLETES. DEVELOPED ALONG SIDE THE MODEL FITTED WITH THE CARBON MONOSTAY, IT ENJOYS THE SAME BASIC FEATURES AS SPECIFICALLY REQUESTED BY SOME PROFESSIONAL RIDERS. THE MAIN DIFFERENCE BEING THE STIFFENED REAR TRIANGLE TO PROVIDE A QUICK RESPONSE TO CHANGES OF PACE AND OUT OF THE SADDLE ACCELERATIONS. TRULY UNIQUE...

928 CARBON WHITE - 1949, 1952, 1998: the years in which Bianchi won both the Giro and the Tour in the same year.

SIMPLY A CUT ABOVE, IT IS THE FRAME WHICH GAVE VERA CARRARA THE GOLD MEDAL IN THE POINTS RACE DURING THE 2005 WORLD CHAMPIONSHIPS. THE CARBON FIBRE STRUCTURE FOLLOWS THE REPARTO CORSE EXCLUSIVE DESIGN AND WITH ITS SLOPING GEOMETRY; OVERSIZED DOWN TUBE AND SEMI-INTEGRATED COMPACT STEERING SYSTEM 1" 1/8 HEAD TUBE GIVES THE FRAME BETTER STABILITY AND REACTIVITY. THE REAR MONOSTAYS ARE DESIGNED TO WITHSTAND LATERAL DEFLECTIONS AND PROVIDE EXCELLENT POWER TRANSFER TO THE REAR TRIANGLE AND DRIVE TRAIN.

PINELLA BORON - The legendary mechanic of Fausto Coppi.

CONSTRUCTED FROM HLSA (HIGH STRENGTH LOW ALLOY) MICRO-ALLOY STEEL, FEATURING A TENSILE STRENGTH OF 1.400 N/MM². THANKS TO THE USE OF TRIPLE-BUTTED TUBING AND LTP LOW TORSION SPECIAL PROFILES, IT ENSURES LIGHTNESS AND RIGIDITY DURING ACCELERATION. A SPECIAL CATAPHORESIS SURFACE TREATMENT PROTECTS THE SURFACE (INTERNALLY AND EXTERNALLY) MAKING IT BOTH DURABLE AND CORROSION RESISTANT.

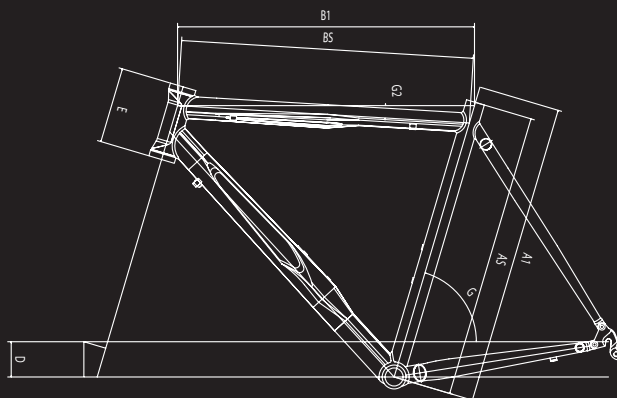

MIS.SLP							
A1	AS	B1	BS	D	E	G	C2
490	460	523	509	58	110	74.5°	7"
500	470	524	512	58	110	74.5°	6"
510	480	526	515	58	110	74°	5"
520	490	530	520	63	110	74°	4.5"
530	500	535	523	68	125	74°	5.5"
540	510	540	530	68	125	74°	4.5"
550	520	550	538	68	140	73.5°	5"
560	530	555	545	68	140	73.5°	4"
570	540	560	550	68	155	73.5°	5"
580	550	570	560	68	155	73°	4"
590	560	575	563	68	175	73°	5"
600	570	580	570	68	175	73°	4"
610	580	585	572	68	195	72.5°	5"
620	590	590	579	68	195	72.5°	4"
630	600	595	583	68	210	72.5°	4.5"

FRECCIA CELESTE HA, X6B04, COLOUR CX. ALSO AVAILABLE IN COLOUR KT.

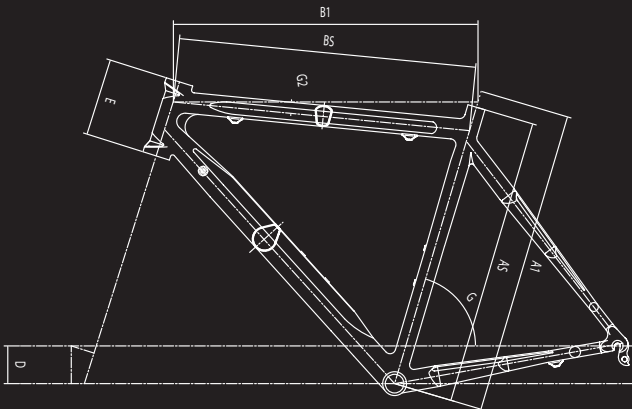

MIS SLP							
A1	AS	B1	BS	D	E	G	G2
500	480	525	511	58	110	74.5°	7°
530	500	535	522	68	125	74°	6°
550	520	550	537	68	140	73.5°	6°
580	550	570	560	68	155	73°	4°
610	580	585	574	68	195	72.5°	5°

928 CARBON WHITE, X6B07, COLOUR A6

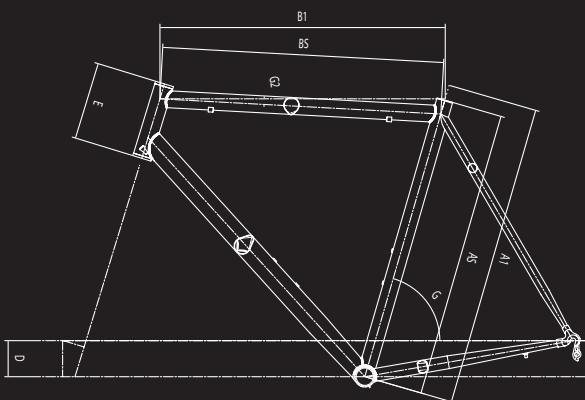

MIS SLP							
A1	AS	B1	B5	D	E	G	G2
490	460	523	510	58	100	74.5°	7°
500	470	524	512	58	100	74.5°	6°
510	480	525	515	58	100	74°	5°
520	490	530	521	63	100	74°	4°
530	500	535	525	68	110	74°	5°
540	510	540	531	68	116	74°	4°
550	520	550	540	68	125	73.5°	4°
560	530	555	545	68	130	73.5°	4°
570	540	560	550	68	142	73.5°	4°
580	550	570	560	68	150	73°	4°
590	560	575	565	68	162	73°	4°
600	570	580	570	68	168	73°	4°
610	580	585	574	68	180	72.5°	4°
620	590	590	579	68	190	72.5°	4°
630	600	595	584	68	200	72.5°	4°

PINELLA BORON, X6B10, COLOUR CZ

MTB FRAMESET

OETZI ALU - Our most popular ancestor, the man of Similaun. A man of the mountains, nimble and tough, just like this cycle.

DESIGNED BY BIANCHI'S REPARTO CORSE ENGINEERS IN COOPERATION WITH THE RIDERS, ATHLETES FOUND ON ONLY THE TOUGHEST COURSES AROUND THE WORLD, THIS FRAME IS MADE WITH A VERY SPECIAL 7000 SERIES ALUMINIUM ALLOY. STUDYING DIFFERENTIATED SECTIONS AND MOMENTS OF INERTIA, THE TRIPLE-BUTTED TUBES FOLLOW THE REPARTO CORSE EXCLUSIVE DESIGN, THE CROSS COUNTRY GEOMETRY IS OPTIMISED FOR COMPETITION, ALL OF THIS MAKING AN OUTSTANDING PRODUCT. ALL SPECIAL PARTS ARE MANUFACTURED USING CNC MACHINES. THE STRUCTURAL FOAM INJECTION, FOUND IN THE MOST STRESSED AREAS OF THE FRAME, AND THE PHOSPHOR-CHROMATE SURFACE TREATMENT REMARKABLY INCREASES THE DURABILITY OF THIS TRULY SPECIAL FRAME.

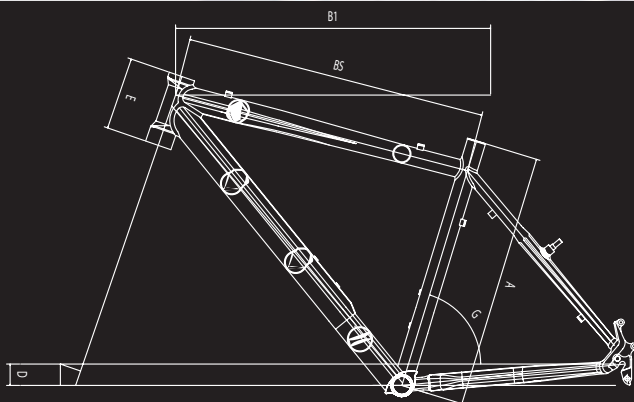

MIS.					
A	B1	BS	D	E	G
380	540	525	40	125	73°
430	570	546	40	125	73°
480	590	565	40	125	73°
530	615	593	40	135	73°

OETZI 9000 ALU, X6B51, COLOUR MG. ALSO AVAILABLE IN COLOUR DB.

2006 THE BIANCHI WORLD - TOTAL CELESTE.

CYCLES / FRAMES / COMPONENTS / ACCESSORIES / CLOTHING / NEWS / TEAM / CLUB / R&D / CORPORATE



TEAM LIQUIGAS BIANCHI - TOUR DE FRANCE, 05.07.2005

EXPLORE THE BIANCHI WORLD ON THE OFFICIAL WEBSITE...

www.bianchi.com

TOTALLY RENEWED, IT IS THE WEB MEETING POINT TO ALWAYS STAY IN TUNE WITH BIANCHI AND DISCOVER, ON-LINE, NEWS AND TEAM RESULTS, THE TECHNOLOGIES AND THE MATERIALS EMPLOYED TO MANUFACTURE THE 'SPECIALISSIME' FROM REPARTO CORSE, THE SPECIAL INITIATIVES AND THE EXCLUSIVE INTERVIEWS. YOU WILL ALSO RECEIVE DIRECTLY ON YOUR E-MAIL INBOX THE NEWSLETTER AND THE BIANCO CELESTE MAGAZINE, CONTAINING UP-TO-DATE INFORMATION ABOUT WHAT'S GOING ON AROUND THE FACTORY.

... AND CHOOSE YOUR CELESTE ON BIANCHI STORE.COM

www.bianchistore.com

FOR THOSE WHO CRAVE IT, THE ON-LINE OFFICIAL BRAND STORE HAS A NEW SPACE AND A NEW ADDRESS WHERE YOU CAN EASILY BUY ALL BIANCHI ACCESSORIES AND PREVIEW ALL THE NEW GADGETS: FROM THE JERSEYS OF THE CHAMPIONS TO THE TECHNICAL ACCESSORIES, FROM THE LEISURE TIME CLOTHING UP TO THE LATEST PUBLICATIONS. EACH MONTH A SHOP WINDOW OF NOVELTIES AND SPECIAL OFFERS, TOO GOOD TO MISS!

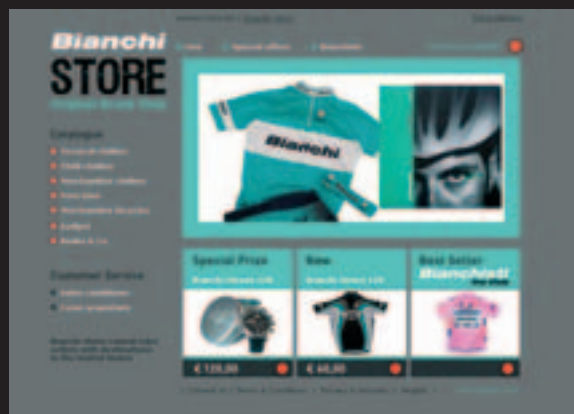

THE CLUB. TWO WHEELS AND A CELESTE JERSEY.

CELESTE IS NOT ONLY A COLOUR, IT IS AN ATTITUDE. SPECIALISSIMA IS NOT YOUR TWO-WHEELS, BUT RATHER A PASSION; GROUP IS NOT A PELOTON OF SHAVEN LEGGED RIDERS, IT MEANS THE FANS WHO ARE ALWAYS IN SEARCH OF THE EAGLE CREST. YOU ARE 'BIANCHISTA' A MEMBER OF ONE OF THE PROUDEST CLUBS EVER SEEN. WE KNOW IT AND WE HAVE CREATED FOR YOU A SPECIAL WORLD, WITH A PASSWORD-PROTECTED AREA RICH IN DEDICATED INFO AND CONTENTS.

VISIT THE OFFICIAL WEBSITE, AND JOIN THE CLUB!
BIANCHISTI. PASSION IN AN UNLIMITED EDITION.



AUSTRALIA

BIKESPORTZ IMPORTS PTY LTD
23C-23D INDUSTRIAL DRIVE
BRAESIDE 3195 VICTORIA
AUSTRALIA
TEL: +61 3 9586 1600
FAX: +61 3 9587 6951
E-MAIL: BIANCHI@BIKESPORTZ.COM.AU

AUSTRIA

CYCLEUROPE INDUSTRIES S.A.
161, RUE GABRIEL PÉRI
F 10104 ROMILLY SUR SEINE
FRANCE
TEL: +43 (0)316 58 40 64
FAX: +43 (0)316 81 88 77
E-MAIL: INFO@CYCLEUROPE.AT

BELGIUM / LUXEMBOURG

CYCLEUROPE INDUSTRIES S.A.
161, RUE GABRIEL PÉRI - BP 108
F 10104 ROMILLY SUR SEINE
FRANCE
TEL: +33 3 25393939
FAX: +33 3 25393755
E-MAIL: CYCLEUROPE@CYCLEUROPE.FR

BRAZIL

ABDUCH NADIA ME
RUA TITO, 1641 VILA ROMANA
05051-000 SAO PAULO
BRAZIL
TEL/FAX: +55 11 38321506
E-MAIL: BIANCHIBRASIL@TERRA.COM.BR

CANADA

BIANCHI USA INC.
21325A CABOT BOULEVARD
94545 HAYWARD
CALIFORNIA
USA
TEL: +1 510 264 1001
FAX: +1 510 856 0338
E-MAIL: INFO@BIANCHIUSA.COM

CZECH REPUBLIC

LOM TRADING
POD JAROVEM 2035/26
13000 PRAHA 3
CZECH REPUBLIC
TEL/FAX: +42 0274 819287
E-MAIL: LOMTRADING@VOLNY.CZ

CYPRUS

POLYS POUIMBOURIS & CO. LTD
MAKEDONITISSIS 84 ABC
STROYVLOS - NICOSIA
CYPRUS
TEL: +357 22 511171
FAX: +357 22 492024
E-MAIL: POLYSP@CYTANET.COM.CY

DENMARK

CYCLEUROPE DANMARK
BØRGE KILDEMOES
CYKELFABRIK A/S
ALBANIVEJ 7, NR. LYNDELSE
DK 5792 ÅRSLEV
DENMARK
TEL: +45 63 902620
FAX: +45 63 900625
E-MAIL: INFO@KILDEMOES.DK

ESTONIA

BALTI AUTOOSADE AS
MUSTAMAE TEE 18A
TALLINN 10617
ESTONIA
TEL: +372 6 200600
FAX: +372 6 200699
E-MAIL: AINJ@AUTOPARTS.EE

FINLAND

CYCLEUROPE FINLAND OY
SARKATIE 1A
01720 VANTAA
FINLAND
TEL: +358 9 8492055
FAX: +358 9 84920544
E-MAIL: INFO@CYCLEUROPE.FI

FRANCE

CYCLEUROPE INDUSTRIES S.A.
161, RUE GABRIEL PÉRI - BP 108
F 10104 ROMILLY SUR SEINE
FRANCE
TEL: +33 3 25393939
FAX: +33 3 25393755
E-MAIL: CYCLEUROPE@CYCLEUROPE.FR

GERMANY

CYCLEUROPE INDUSTRIES S.A.
161, RUE GABRIEL PÉRI
F 10104 ROMILLY SUR SEINE
FRANCE
TEL: +49 (0) 1805 123492
FAX: +49 (0) 1805 123493
E-MAIL: INFO@CYCLEUROPE.DE

NETHERLANDS

CYCLEUROPE INDUSTRIES S.A.
BIANCHI DIVISION
MARSTEDEN 29
NL 7547 TE ENSCHEDE
THE NETHERLANDS
TEL: +31 53 4280815
FAX: +31 53 4280820
E-MAIL: CYCLEUROPE@CYCLEUROPE.NL

HONG KONG

CHEUNG KEE CYCLE COMPANY
N° 1B, G/F, FUK YIP BUILDING
N° 12, KIK YEUNG ROAD
YUEN LONG
N.T. HONG KONG SAR
TEL: +852 24746794/24753047
FAX: +852 24494949
E-MAIL: CKCYCLE@NETVIGATOR.COM

ITALY

CYCLEUROPE ITALIA SRL
VIA DELLE BATTAGLIE, 5
24047 TREVIGLIO - BERGAMO
ITALIA
TEL: +39 0363 3161
FAX: +39 0363 303680
E-MAIL: CYCLEUROPE@CYCLEUROPE.IT

JAPAN

CYCLEUROPE JAPAN CO. LTD.
KAIKA BLDG.
2F-7-1 2 CHOME SOTOKANDA
CHIYODA-KU
TOKYO 101
JAPAN
TEL: +81 (03) 3255-2431
FAX: +81 (03) 3255-2737
E-MAIL: INFO@CYCLEUROPE.CO.JP

MALTA

MAGRI CYCLES & SPARES
148 B 155, EUCHARISTIC CONGRESS ROAD
MST/07 MOSTA
MALTA
TEL: +356 21 414399
FAX: +356 21 436377
E-MAIL: MAGRICYC@NEXTGEN.NET.MT

NEW CALEDONIA

CYCAL SARL
6 RUE DE TOURVILLE
QUARTIER LATIN BP 585
98845 NOUMEA CEDEX
N. CALEDONIE
TEL: +687 276624
FAX: +687 259896
E-MAIL: CYCAL@LAGOON.NC

NEW ZEALAND

INTERVELO NEW ZEALAND
74 HATAITAI ROAD
HATAITAI - WELLINGTON
NEW ZEALAND
TEL: +64 4 3864074
E-MAIL: INFO@BIANCHI.CO.NZ

NORWAY

CYCLEUROPE NORGE AS
P.O. BOX 385
N-4303 SANDNES
NORWAY
TEL: +47 51-604500
FAX: +47 51 675722
E-MAIL: INFO@DBS.NO

PORTUGAL

VIEIRA GRACA & CA LDA
LARGO DO TEATRO, 37
2200-032
ALFERRAREDE ABRANTES
PORTUGAL
TEL/FAX: +351 2 41 371902
E-MAIL: VIEIRA.GRACA@IOL.PT

SERBIA AND MONTENEGRO

HYDROART
NJEGOSEVA 45
11000 BELGRADE
SERBIA AND MONTENEGRO
TEL/FAX: +381 11 2441310
E-MAIL: KILIR@EUNET.YU

SINGAPORE

KIAN HONG CYCLE PTE LTD.
3 KAKI BUKIT ROAD 1
B1-05 EUNOS TECHNOLINK
SINGAPORE
TEL: + 65 67495787
FAX: + 65 67495789
E-MAIL: SMIEK@KHICYCLE.COM.SG

SLOVENIA

SKUPINA CLAAS D.D. LJUBLJANA
ZALOSKA CESTA 171
1000 LJUBLJANA
SLOVENIA
TEL: +386 1 5484770
FAX: +386 1 5484781
E-MAIL: PETER.ZAVASNIK@CLAAS.SI

SOUTH AFRICA

CYCLING J&J (PTY) LTD
169 MEERLUST STREET
WILLOW GLEN
SOUTH AFRICA
TEL: +27 (012) 807 5570
FAX: +27 (012) 807 4267
E-MAIL: INFO@JJCYCLING.CO.ZA

SPAIN

K. MOTOR DEALER S.L.
PARQUE INDUSTRIAL EUROPOLIS
CALLE Z, N° 12-14
28230 LAS ROZAS - MADRID
SPAIN
TEL: +34 91 637 70 97
FAX: +34 91 637 72 64
E-MAIL: INFO@MOTORDEALER.COM

SWEDEN

CYCLEUROPE SVERIGE AB
BIRGER SVENSSONS VÄG 28
S 43282 VARBERG
SVERIGE
TEL: +46 (0) 340 86000
FAX: +46 (0) 340 89672
E-MAIL: INFO@CYCLEUROPE.SE

SWITZERLAND / LIECHTENSTEIN

ECCSA SA.
VIA LA SANTA, 17
CH-6962 LUGANO-VIGANELLO
SWITZERLAND
TEL: +41 91 7805903
FAX: +41 91 7805901
E-MAIL: CENTROBIANCHI@BLUEWIN.CH

TAIWAN

FIRST FLAG ENTERPRISE CO., LTD.
N° 1 LANE-311 KUANG-FU ROAD
TAICHUNG CITY, 407
TAIWAN
TEL: +886 436020688
FAX: +886 430620389
E-MAIL: FIRSTFLAG@SEED.NET.TW

THAILAND

UWC LTD. (TCA)
3656/35-36, 11TH FLOOR GREEN TOWER
RAMA 4 RD., KLONGTOEY
BANGKOK 10110
THAILAND
TEL: +66 2 3673470
FAX: +66 2 3673482 /+66 2 3673243
E-MAIL: KANATE@UNIWAVE.NET

UNITED KINGDOM

CYCLEUROPE UK LTD
BIANCHI DIVISION
21-23 MILL STREET
MK 40 3EU BEDFORD
GREAT BRITAIN
TEL: +44 1 234245929
FAX: +44 1 234270562
E-MAIL: BIANCHI.UK@CYCLEUROPE.COM

UNITED STATES OF AMERICA

BIANCHI USA INC.
21325A CABOT BOULEVARD
94545 HAYWARD
CALIFORNIA
USA
TEL: +1 510 264 1001
FAX: +1 510 856 0338
E-MAIL: INFO@BIANCHIUSA.COM